

## FREMONT LED POST TOP INSTRUCTIONS

Issue 06 on 6<sup>th</sup> March 2021

**THANK YOU** for buying this product. To help ensure it gives complete satisfaction please install it according to these instructions and then pass the instructions to the appropriate person for retention and future reference.

**SAFETY** This is a mains powered product. It is designed to be installed by suitably qualified personnel only and in accordance with the applicable building and electrical regulations. Before installation or maintenance the electrical supply to the product must be isolated.



**INSTALLATION SUPPORT** If installation advice or accessories are required please contact us at the above address. We will do our best to help. When reporting a suspected fault or seeking installation support the problem is likely to be resolved most quickly if you have full product details to-hand, as well as details of when and where it was purchased.

### DIMENSIONS

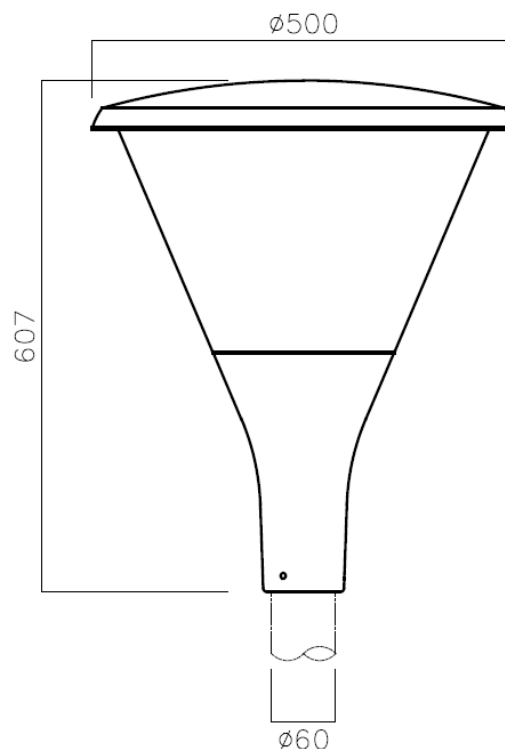

### LUMINAIRE INSTALLATION

1. Prepare column & mains rated power supply.  
**Note!** This product is suited to a 60mm diameter fixing, so a column adaptor may be required to achieve this.
2. Offer the luminaire to the mains supply cable & terminate using the IP65 in line cable connector, ensuring correct polarity is observed.  
**Note!** This luminaire must be earthed.
3. Feed any excess cable back into the column, locate the luminaire onto the column & secure using the grub screws.
4. Reconnect power supply & check for correct operation.  
**Note!** Luminaires fitted with electronic drivers are exempt from insulation resistance tests as this may cause irreparable damage.

### MAINTENANCE

1. Cleaning should be carried out at regular intervals so as not impair photometric or thermal performance.